

EFFECTIVE:
23-JAN-20

SUPERSEDES:
28-MAY-19

DIMENSION PRINT
WORLD MOTOR AUTO DUTY
FRAME: 444U, 445U
BASIC TYPE: JDE

PRINT:
08-1198

SHEET:
1 OF 1

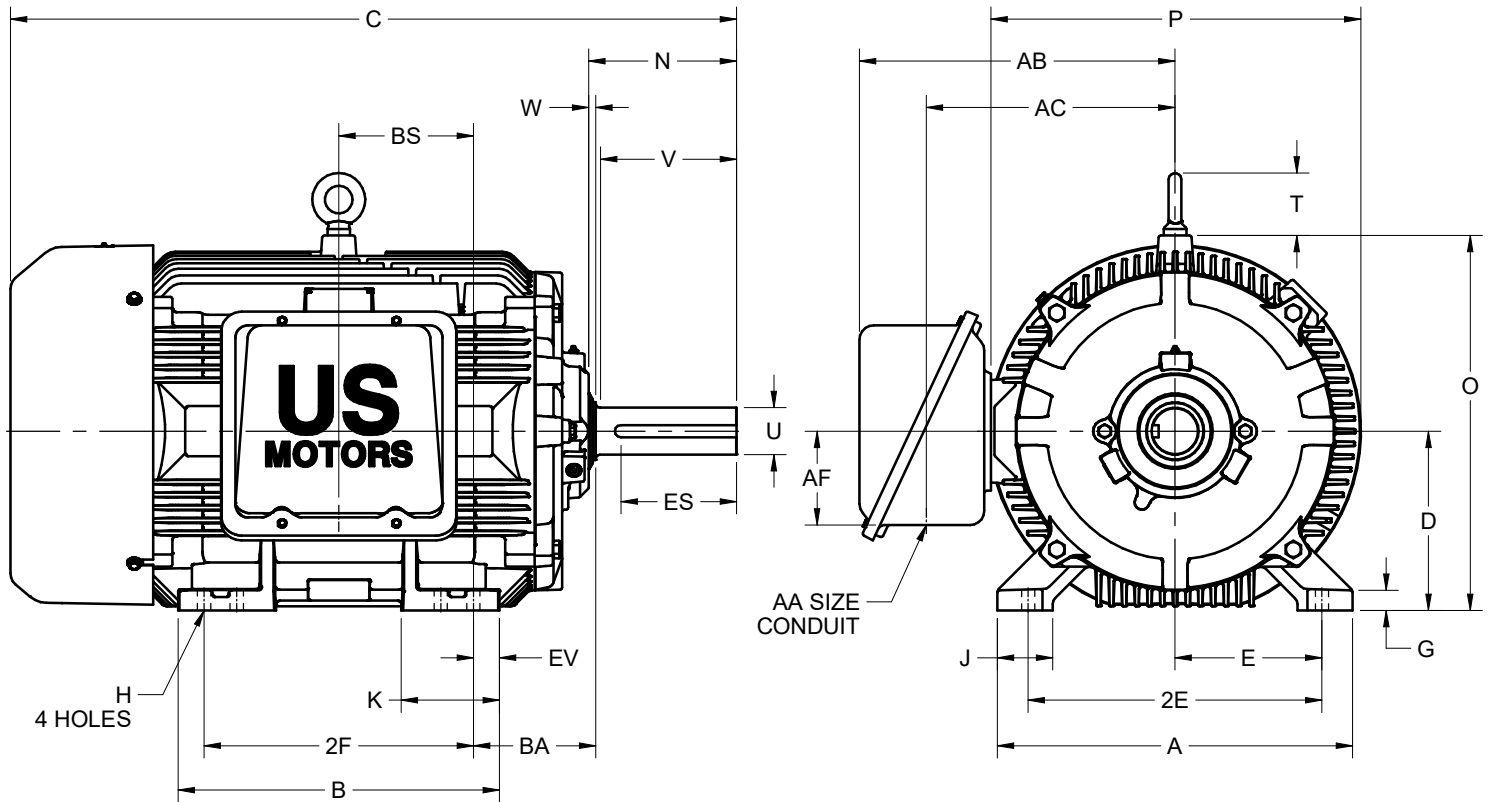

ALL DIMENSIONS ARE IN INCHES AND MILLIMETERS

UNITS	A	B	C	D -.06	E	2E ±.03	G	H +.05	J	K	N	O	P ²
IN	21.75	19.69	44.50	11.00	9.00	18.00	1.25	.81	3.38	6.00	9.09	23.00	22.97
MM	552	500	1130	279	229	457	32	21	86	152	231	584	583

UNITS	T	U -.001	V MIN	W	AA	AB	AC	AF	BA	BS	EV	ES MIN	SQ KEY
IN	3.81	2.875	8.25	.44	3 NPT	19.34	15.25	5.75	7.50	8.25	1.59	7.03	.750
MM	97	73.03	210	11		491	387	146	191	210	40	179	19.05

FRAME	UNITS	2F ±.03
444U	IN	14.50
	MM	368
445U	IN	16.50
	MM	419

1. DIMENSIONS MAY VARY .25" DUE TO CASTING AND/OR FABRICATION VARIATIONS
2. LARGEST MOTOR WIDTH
3. STANDARD ASSEMBLY POSITION F-1 IS SHOWN. F-2 IS PROVIDED WHEN SPECIFIED. CONDUIT OPENING MAY BE LOCATED IN STEPS OF 90° REGARDLESS OF THE LOCATION
4. TOLERANCES ARE SHOWN IN INCHES ONLY

08-1198/A

Nidec Motor Corporation
St. Louis, Missouri

INFORMATION DISCLOSED ON THIS DOCUMENT IS CONSIDERED PROPRIETARY AND SHALL NOT BE REPRODUCED OR DISCLOSED WITHOUT WRITTEN CONSENT OF NIDEC MOTOR CORPORATION



ISSUED BY
R. TIMMERMANN
APPROVED BY
T. MIDDLETON

IHP_DP_NMCA (MAR-2011) SOLIDEDGE